

JOINTER

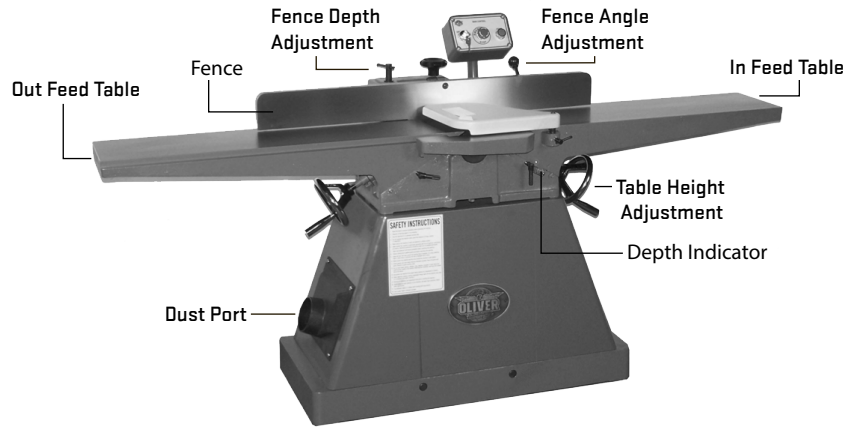

Description + Intended Use

The jointer is used to surface wood flat and square. There are two parallel bed set at slightly different levels provide a reference for the wood. A rotating cutter head placed in front of the outfeed table removes material from the wood at the same level as the outfeed table.

Allowable Materials

Dry, clean wood ONLY

Operation

1. Using the guide on the jointer adjust the infeed table to the appropriate depth.
2. Adjust the fence to the appropriate angle if needed.
3. With the dust collection on, turn on the jointer.
4. Using firm pressure down and into the fence begin feeding the workpiece towards the cutter head.
5. Once the workpiece has moved past the cutter head, continue pressing down and into the fence in front of the cutter head.
6. Continue feeding the material through until completely past the cutter head maintaining pressure in front of the cutter.
7. If necessary, continue making passes until the workpiece is at least flat at all four corners.

Safety Guidelines

1. Use Paddles, push sticks and push blocks whenever possible.
2. Never place your hands within 4" of the cutter head.
3. Never remove the blade guard for any reason.
4. Always surface the concave face of a board, i.e. make sure there are at least two points of contact between the workpiece and the table at all times.
5. If possible orient the grain so that it runs down to the back of the workpiece.
6. Make sure there is at least 1" of reference material across either the table or fence at all times.
7. Never joint anything under 12" long.